

MultiColor Flex 14

# Installation instructions

The MultiColor Flex 14 is encased in opaque, white plastic, but its low height nevertheless provides it with a visible pitch, and it is therefore particularly suited for indirect lighting installations where the actual conductor film should not be visible.

Let's design our future.

**Döllken**  
Lighting

.....  
we create.  
we innovate.

SURTECO GROUP

# General information

These installation instructions must absolutely be followed for claims under the guarantee to be recognised after purchasing the product.

Please ensure that every person installing our products will read and take into account these instructions. Failure to observe these instructions will render the guarantee null and void and may lead to defects in the product or its functionality both immediately and in the longer term.

Please check on receipt of the goods that they are in perfect

condition and functional. We carry out 100% final checks on products and documentation prior to dispatch of the LED strips. It will not be possible to exclude installation errors should the strips be partially or totally dysfunctional after installation.

If you have queries or experience problems during installation after reading these instructions, please consult our Sales or Application Division should you have queries or experience problems during installation after reading these instructions. We will gladly provide assistance.

## Contact

Julia Manasse  
Tel +49 (0) 36 43 / 41 70-400  
[info@doellken-lighting.com](mailto:info@doellken-lighting.com)

# Safety instructions

- Installation of the products shall be carried out exclusively by suitably qualified electrical technicians and with due regard to these instructions, the technical data sheets and compliant with all national standards and statutory requirements.
- Döllken Lighting accepts no liability for damage caused by improper handling during installation or general deployment of the product.
- Any unauthorised changes to the products will render relevant certificates and warranty agreements null and void.
- Be sure to isolate from mains voltage before installation or servicing.
- Ensure that the connection of the connecting cable to mains supply/controller complies with the wiring regulations at your location.
- The electronic supply must be in agreement with the given power requirements for the specific module lengths. For individual specifications, please refer to the technical datasheets for the specific product version.
- The LED modules should only be operated with SELV controllers carrying the CE mark and complying at least with EN-61347-2-13. The controllers should include the following protection: Short-circuit, overload and over-temperature protection. Ensure that the test mark is that of an independent authorised test institution.
- The strips may be dimmed using PWM.
- Safe operation is ensured only by electrical connection in parallel. Series connection of the LED modules is expressly not recommended. Non-symmetric voltage drops may result in serious overloading and the destruction of individual modules.
- Prevent electrostatic discharges (ESD) during installation.

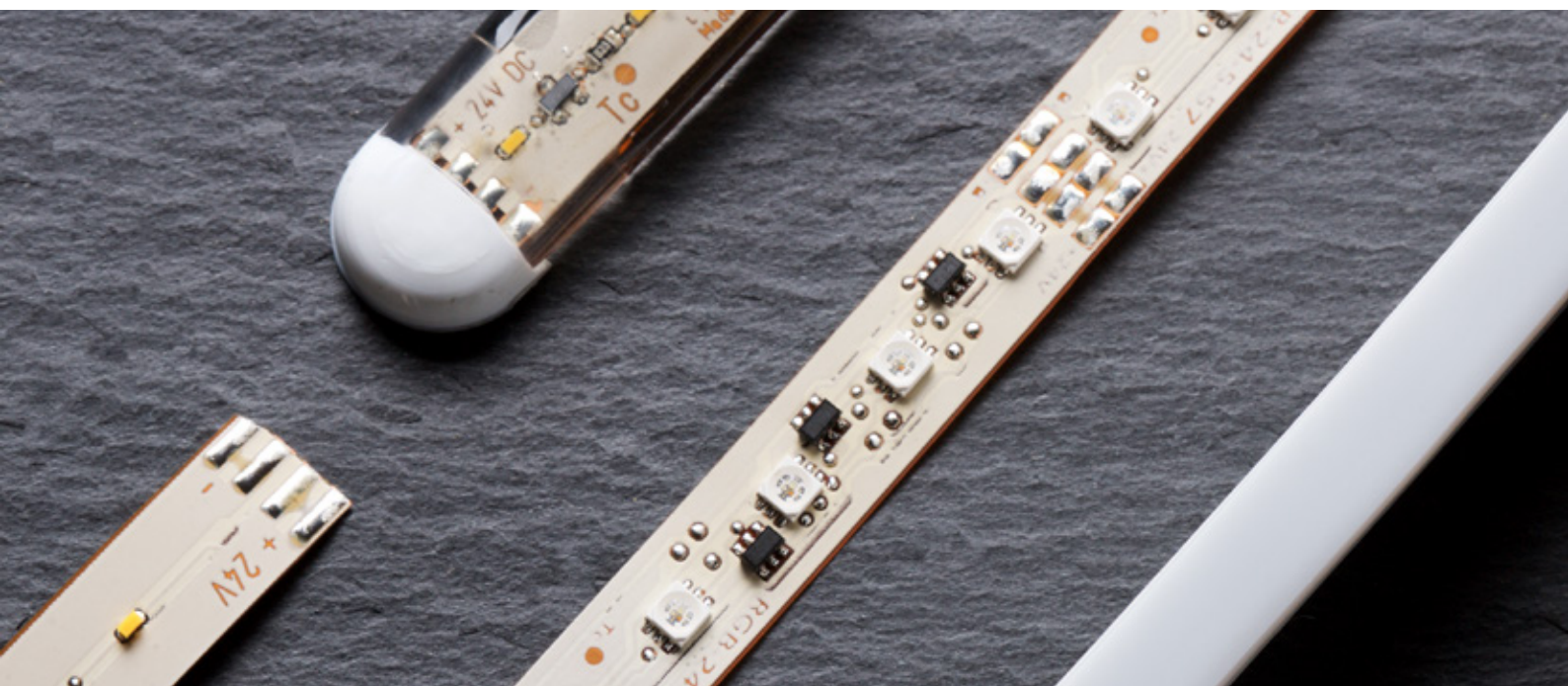

# General installation instructions

Please note the following installation instructions. Non-compliance results in expiry of guarantee claims.

- horizontal bending radius should not be less than  $\geq 200$  mm
- vertical bending radius should not be less than  $\geq 50$  mm
- Always install the product at temperatures between 18°C and 35°C. If necessary, increase the flexibility during installation of the strips by briefly (max. 3 min.) operating at nominal voltage whilst still on the reel.
- Do not bend the modules at sharp angles.
- Do not twist the strips during the installation.
- Do not throw the roll but unwind evenly.
- Avoid bringing force to bear on or tensioning the connections of the strips during installation and secure the wiring to fully exclude this after installation.
- Avoid bringing mechanical forces to bear on any part of the product during installation.
- Exercise particular care when installing lengths in excess of 1.5 m to prevent damage to the conducting foil or electronic components.
- The preferred method of installation will always be using the specific mounting profiles.
- The materials used will allow changes in length of up to  $\pm 2$  mm/m per 10 K temperature difference.

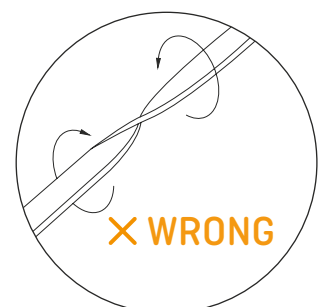
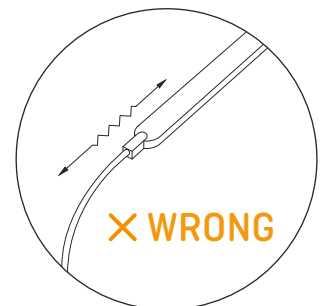
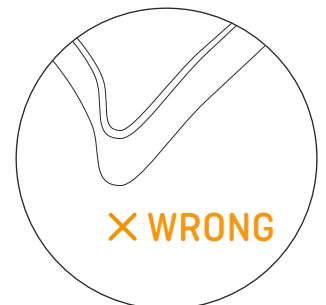
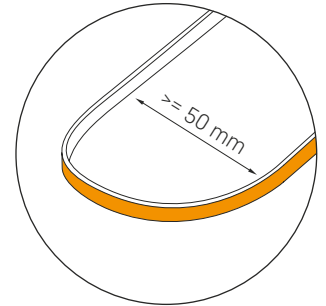
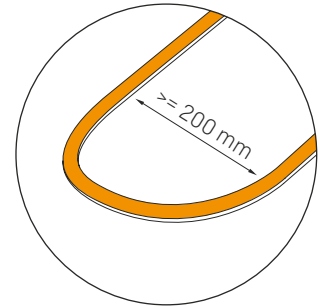

# Installation instructions

## Installation via mounting profile

Step 1

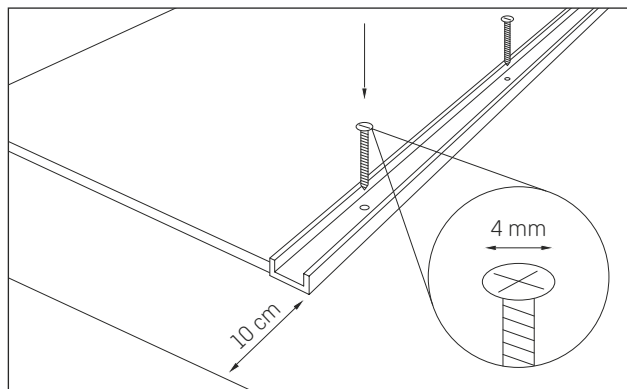

Cut aluminum profile (article no. 5901763) to custom-fit the respective installation and affix with 3 mm counter-sink screws.

To facilitate sliding the LED strips into supports, ensure that approx. 100 mm will be available between the profile and the nearest limiting obstacle.

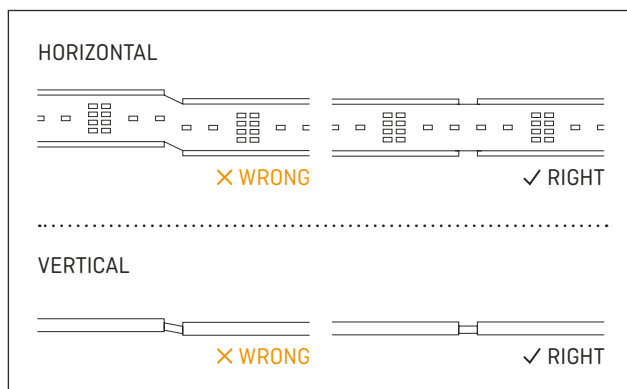

To avoid damaging the strip, the profiles must be horizontally and vertically aligned at the butt joints. They must also be adequately secured to prevent future movement.

Ensure that the substrate under two abutting mounting profiles will not allow shearing displacement at the butt joint since this may damage the conducting foils and electronic components.

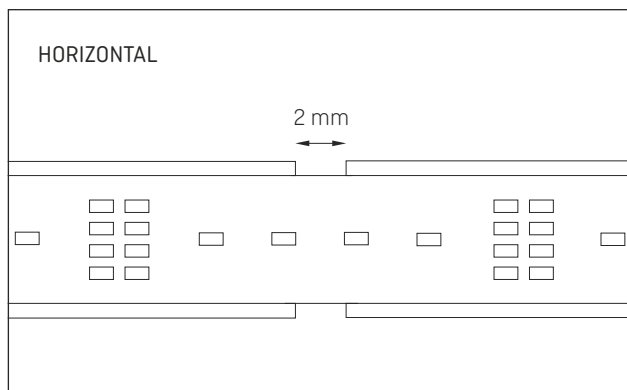

Ensure that expansion joints are included to absorb the expansion tolerances. The products will expand up to 2 mm per meter for each 10 Kelvin difference in temperature.

Please observe the points under step 5 when making and securing the connections.

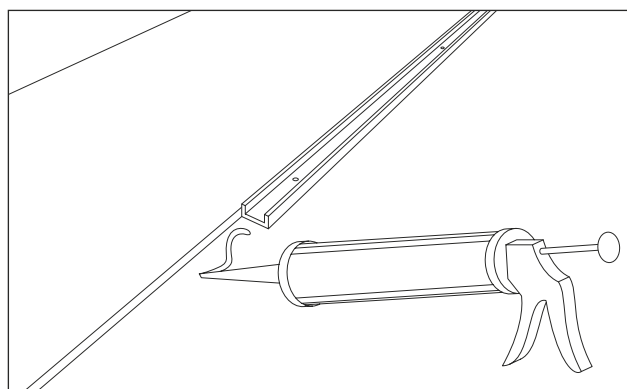

The aluminum profile may alternatively also be glued using suitable mounting adhesives (e.g. Sikaflex 221) and following the specific application notes.

Step 2

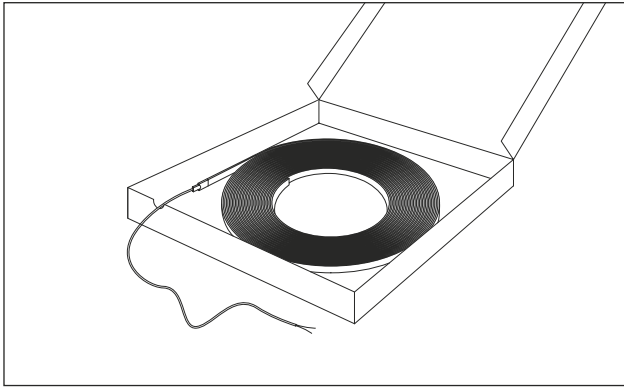

Take the LED module cable from the box, uncoil it and, if necessary, switch on for a while (max. 5 minutes) to raise the temperature of the product to 18 – 30°C for flawless installation.

Step 3

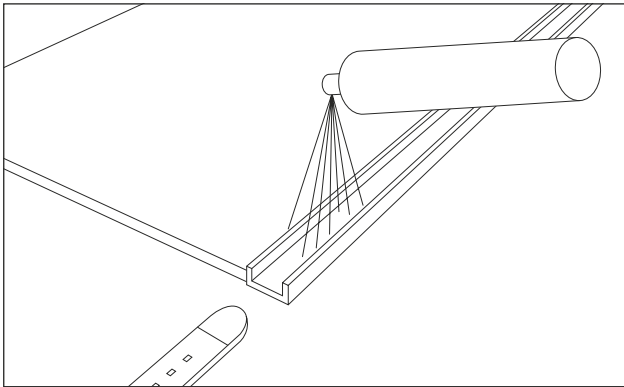

Uncoil the LED module and lay it out at the end of the installed aluminum profile. Use a little silicone spray at the start of the aluminium profile to facilitate insertion.

Cross-check again whether the length of the LED module matches the length of the aluminium profile or installation situation.

Step 4

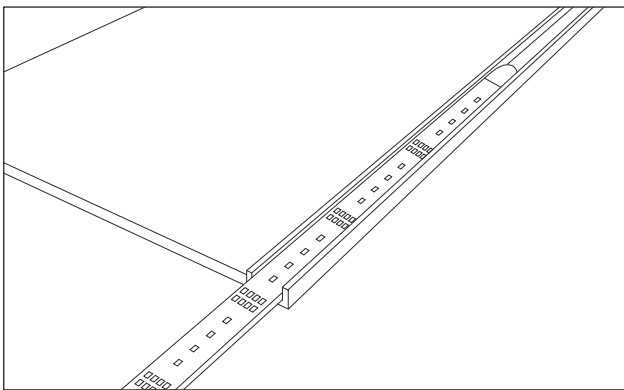

Insert the LED module into the profile end cap first, at a shallow angle and without kinking. Use more silicone spray, as needed.

<p><b>HORIZONTAL CONNECTION</b></p> <p>× WRONG</p>	<p><b>VERTICAL CONNECTION</b></p> <p>× WRONG</p>	<p><b>ENDCAP</b></p> <p>× WRONG</p>
<p>× WRONG</p>	<p>Expansion joint</p> <p>✓ RIGHT</p>	<p>Expansion joint</p> <p>✓ RIGHT</p>
<p>Strain relief</p> <p>✓ RIGHT</p>	<p>Strain relief</p>	<p>Ensure that the strip will also not kink or bend at the connection, end or anywhere else after installation.</p>

Step 5

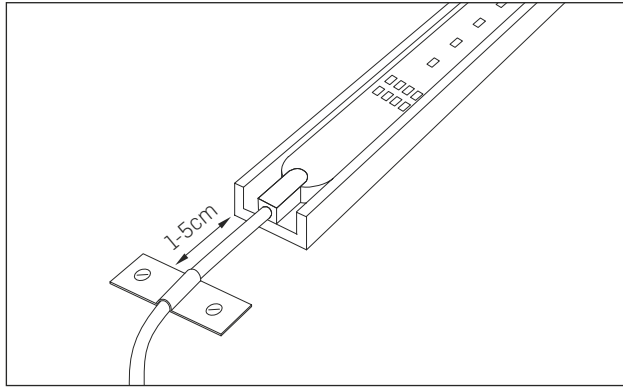

It is imperative that a strain relief be affixed 1 – 5 cm from the connection to relieve any stress at the connection and attached wiring. This will be selected by the installer, depending on installation conditions and substrates. Please contact Döllken Lighting directly should you have queries or need recommendations.

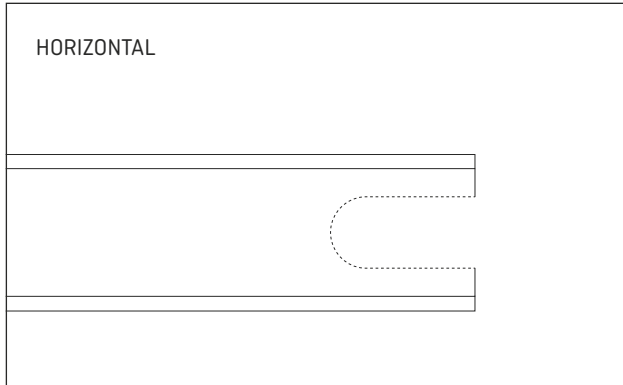

To reduce potential problems we recommend pushing the connection into the profile. It may be necessary to adapt (milling, boring) the aluminum profile for vertical connections or thick cables. Horizontal connections of cables in aluminium profiles may also be secured using adhesives where the connections / cable transitions are.

## Installation via aluminum profile clips

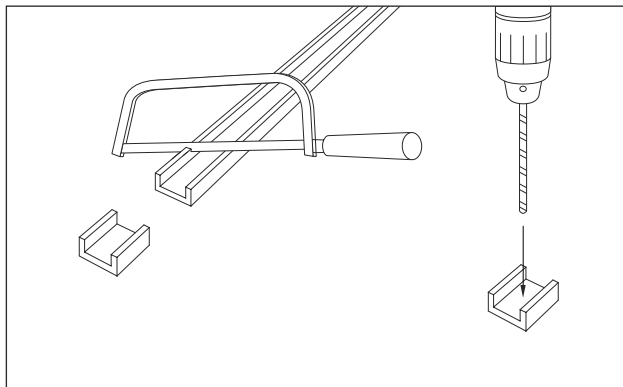

For an installation in various radiuses, the aluminum profiles can also be cut into small pieces and used as clips.

The mounting positions, individual length of the pieces as well as additional drill holes have to be defined to suit the application.

Steps 2 – 5 and the instructions for installation in aluminium profile strips will analogously also apply to installation using clips.

## Installation via direct glueing

It is imperative when gluing the products that the adhesive/sealant remains elastic, yet has adequate strength to bear the stresses and absorb the longitudinal and transverse expansion and contraction. The substrates must furthermore be prepared to the specifications of the manufacturers (e.g. cleaners and primers). The SIKa Sikaflex 221 sealant/adhesive with suitable activator and primer is recommended for reliable gluing.

Please contact Döllken-Lighting directly for detailed information and recommended adhesives.

Steps 2 – 5 and the instructions for installation in aluminium profile strips will analogously also apply to installation using clips.

# Electrical commissioning

After completion of the installation using the described methods, the LED strip must be commissioned in accordance with the corresponding technical data sheets.

Please refer to current technical specifications on our homepage [www.doellken-lighting.com/produkte](http://www.doellken-lighting.com/produkte) or ask your contact person for the correct datasheet as updated to be sure.

Observe the above safety notes when carrying out electrical commissioning, also the following points:

- Ensure that the rated power (Watt) of the controllers and upstream devices matches the power of the relevant LED strips. Ensure that the rated power of the supply exceeds the calculated total power of the specific module by approx. 10%.
- To avoid damage as a result of moisture or temperature, ensure that the protection of upstream devices, controllers and cable connections is based on prevailing environmental conditions.
- Refer to the cables used and the corresponding labels in the packaging for correct wiring of a product.
- The specific product data sheet and the specifications by the manufacturers of electronic equipment are binding in terms of the wiring of LED modules to controllers and upstream devices.